

## Web Services Initiatives

### HostedControls & UNC-CH

By: Matt Horton

VP Technology, Cyrus Technologies, Inc.

- Coming from the dot-com world into the building automation world was eye-opening.
  - First project was to build a Override Billing app for Cushman & Wakefield / Verizon Tower in Tampa
  - Then introduced to i.LON 100 with Web Services (how cool is this thing!?!)
  - Then came to BuilConn2004 and listened to all the commotion around XML
  - Then I talked to lots of Integrators and Controls Contractors and heard how graphics and reporting eats up their margins
  - Finding out most data in buildings is generated and destroyed was the last straw

- We developed HostedControls to do several things
  - Promote the use of Web Services at the building level
  - Build a web based platform for modular applications
  - No Data Left Behind™
  - Measure everything and report frequently
  - Take some of the efforts that drive integrators nuts and do it for them so that they can focus on what they do best, and build for them a constant customer awareness
  - Introduce a recurring revenue model to the industry whose current model is commoditization.
- None of this would be reasonably possible without XML Web Services

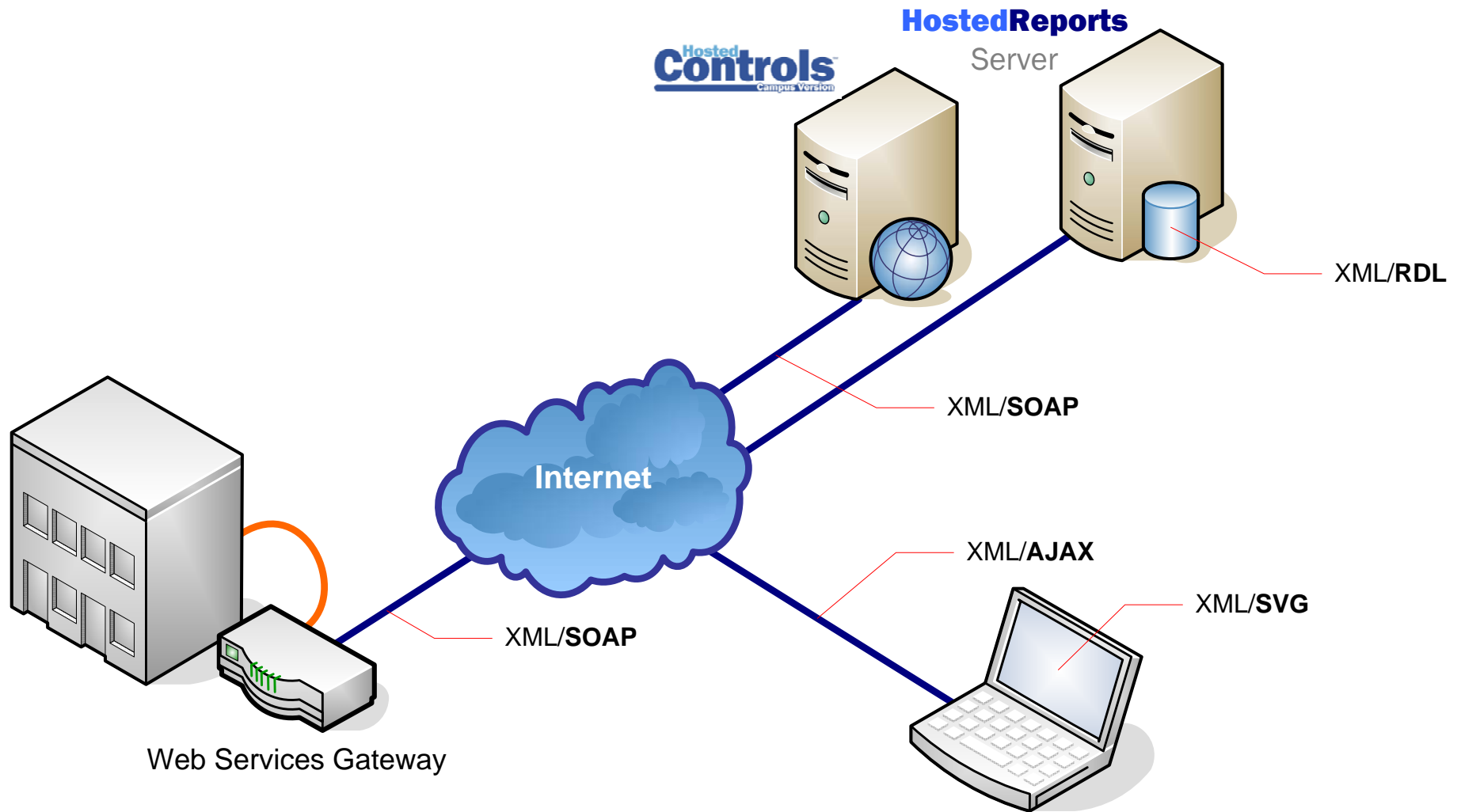

- Create a common building level gateway
- Centralize operator control at the enterprise
- Leave no data behind
- Allow data from any outside source
- Only SOAP & XML on network
- Leading class network/message security
- Full integration with Active Directory
- Web browser only acceptable user app
- Remote alarm distribution
- Version control of all configuration
- SVG only allowable graphic format
- Enterprise class data storage and backup
- No fuss trending
- Robust and centralized scheduling
- Energy management and modeling
- Intelligent Commissioning

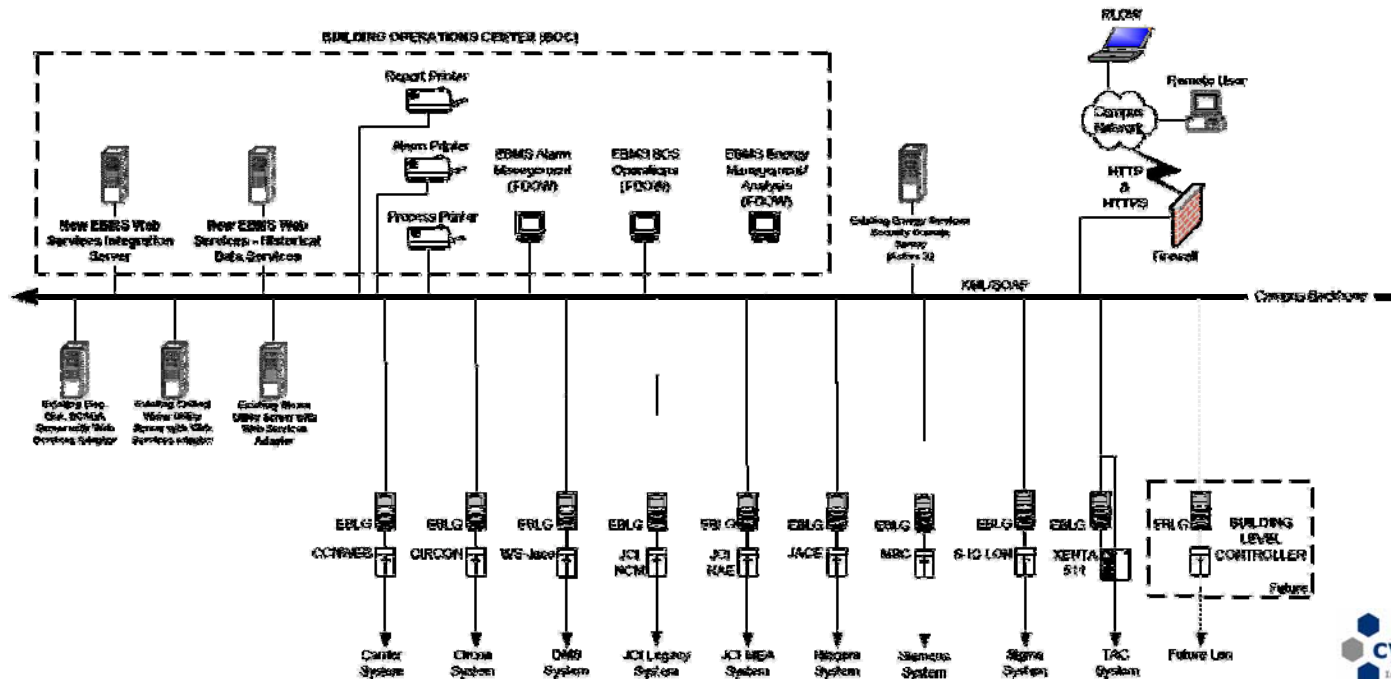

- 140+ Buildings on UNC-CH campus
- 80+ more on the way
- 9 different building control systems
- Inconsistent Front-End HMI
- Too many islands of data
- Inability to aggregate data
- Multiple BAS protocols clogging network
- Lacking configuration documentation
- Reliance on third parties for changes
- Complex and varied remote access
- Multiple service contract pricing
- Differing network security
- Inconsistent terminology
- Sparse web accessibility

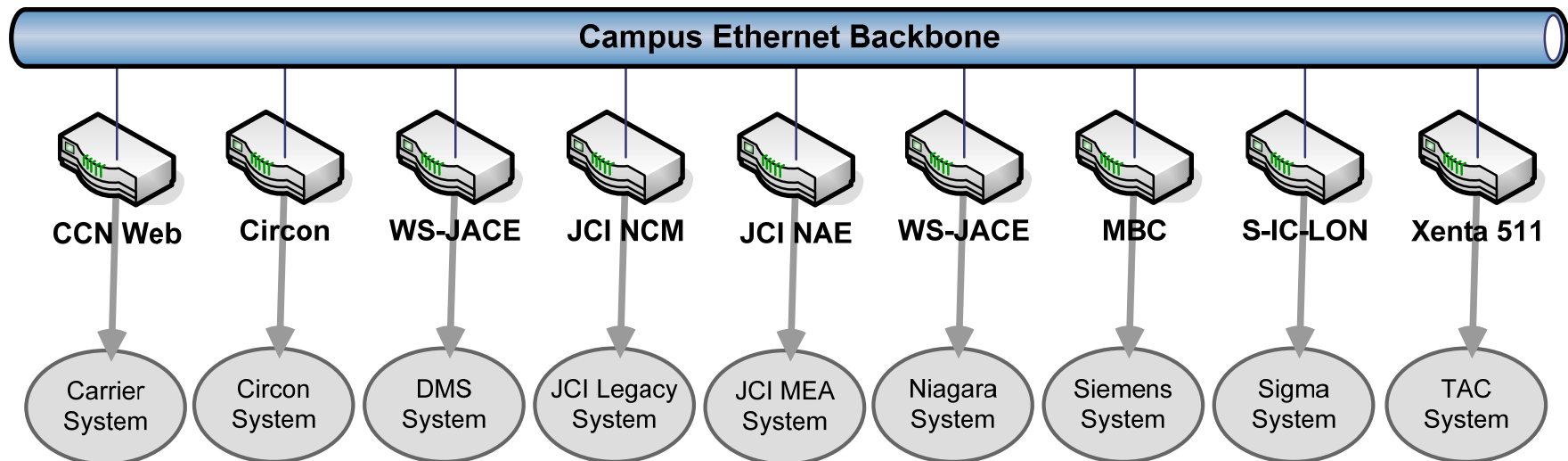

- Centralized CyrusPowered HostedControls / HostedReports integrating:
  - Tridium Niagara Web Services from 70% of Buildings
  - Gridlogix EnNET Web Services from 30% of Buildings
  - Energy Management Analysis Tool via MS Office 2003 Web Services
  - Fuel Prices from External Web Services
  - Weather from External Web Services
  - Entire Campus Configuration via Web Services based Versioning Control
  - Graphics Delivered via Open AJAX & SVG (XML derived)
  - Reports Delivered via Open XML/RDL format
  - All scheduling normalized via XML & iCalendar
  - Geographical Info Systems integration capability via SOAP/XML
- **A veritable Web Services Extravaganza!**

- Individual Buildings on campus can be controlled with permitted mobile computing devices without changing any HostedControls code.
- New buildings can be integrated in a fraction of the time
- Open Command Queuing allows for any future Web Services enabled Energy Management Tool to perform “what-if” scenarios (such as demand limiting) and then a new campus profile can be queued for approval and then executed.
- The point is, that the solution is Web Services based, so any future tools or widgets can be configured to integrate without the need for upgrading to some new version.
- Integrate the entire campus once with Web Services and never have to do it again.
- Upgrade functionality, not entire systems or platforms.

Thank You